

THIS COPY IS PROVIDED ON A RESTRICTED BASIS AND IS NOT TO BE USED IN ANY WAY DETRIMENTAL TO THE INTERESTS OF PANDUIT CORP.

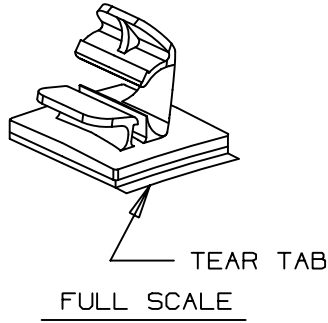
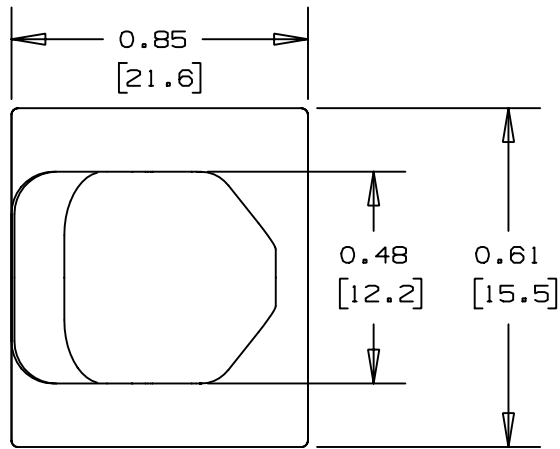

PANDUIT PART NUMBER*	MAXIMUM CABLE DIA. in. (mm)	WEIGHT lbs. (g)/100pcs
LWC19-A	0.1875 (4.8)	0.29 (130)

- NOTES:
 *1) SEE CURRENT PRICE SHEET FOR PART NUMBER SUFFIX DESIGNATION, FOR PACKAGE SIZE.
 2) MOUNT IS DESIGNED TO SUPPORT 0.25 lbs [227g] MAX WEIGHT ON A CLEAN DRY SMOOTH SURFACE.

- TO APPLY LATCHING WIRE CLIP:
 1. REMOVE PROTECTIVE LINER
 2. PLACE IN DESIRED LOCATION
 3. APPLY PRESSURE TO TOP OF LATCHING WIRE CLIP

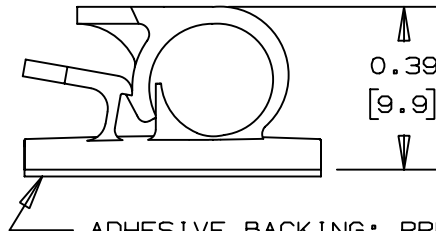

ADHESIVE BACKING: PRESSURE SENSITIVE FOAM 0.04 [1.0] THICK WITH PROTECTIVE LINER TO EXTEND BEYOND EDGE FORMING A TEAR TAB.

NO WARRANTY, EXPRESSED OR IMPLIED, IS MADE BY PANDUIT WITH RESPECT TO ADHESIVE BOND PERFORMANCE, AMONG OTHER THINGS, THE CONDITIONS UNDER WHICH THESE MOUNTS MAY BE APPLIED, AND/OR THE SURFACE TO WHICH THEY MAY BE APPLIED, ARE BEYOND PANDUIT'S CONTROL.

DIMENSIONS IN BRACKETS ARE METRIC [mm]

CAD FILENAME/LAYERS G00239EH_PB_LWC19A_01

PANDUIT CORP. TINLEY PARK, ILLINOIS

LWC19-A, LATCHING WIRE CLIP

UNLESS OTHERWISE SPECIFIED, DIMENSIONAL TOLERANCES ARE:
 (.X) ±0.05 (1.3) (.XXX) ±0.010 (0.25)
 (.XX) ±0.02 (0.5) ANGLES ± 5°

UNLESS OTHERWISE SPECIFIED, ALL DIMENSIONS ARE GIVEN IN INCHES, THIRD ANGLE PROJECTION.

REV	DATE	BY	CHK	DESCRIPTION	ECN	R	CUST	SUP
I	1-7-98	CGSM		CHANGED NOTE 3 ON APPLICATION INSTR.	G00239EH	I		
R	9-20-96	AJV		INITIAL RELEASE	G00239EH	R		

DRAWN BY AJV

MAT'L:

SCALE

2X

DATE 9-20-96

NYLON 6/6

DRAWING NO.

G00239EH

DWG SIZE A